

BCA-AS1428.1 Compliant Nosing



Building Code of Australia (BCA) addresses all the requirements for a building to comply with Australian standards. BCA confers mandatory powers on various Australian Standards to be used in building construction. Any violation of standards will lead to penalties and even declaration of a dwelling as unfit. AS1428.1 – Australian Standard Design for Access and Mobility Part 1 - delineates antislip requirements for stairways and stair nosings.

Safemate's antislip solutions include product range that is designed and manufactured to comply with BCA standards. These products have been tested by accredited testing laboratories for the features and properties as per prescribed Australian Standards.

BCA compliant antislip solutions by Safemate are based on stair nosings and cappings with features derived from, and compliant with, AS1428.1 for stair treads and nosings.

Features:

- > Profile Manufactured and designed to fit stairs as in AS 1428.1
- > Stair nosings do not project beyond the face of the rise
- > Available for both vertical stairs, and for stairs with backward splay
- > A luminance contrast to provide highly visible tread/riser intersection
- > Our range of colours ensures we our product will provide a luminance contrast exceeding mandated 30% against all stairs
- > Optional photoluminescent (Glow in the Dark) version renders BCA compliant stairs and pathways with high visibility in dark for many hours for safest egress in emergency situations
- > Engineered for snug fit

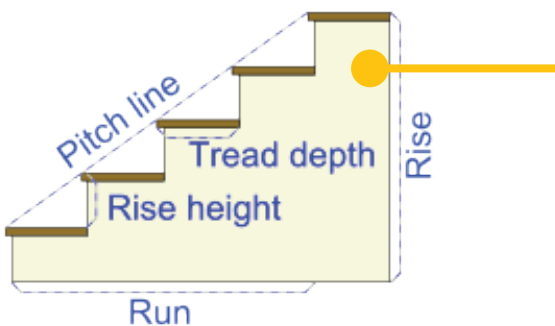

A typical staircase and terms used to describe the various sections.

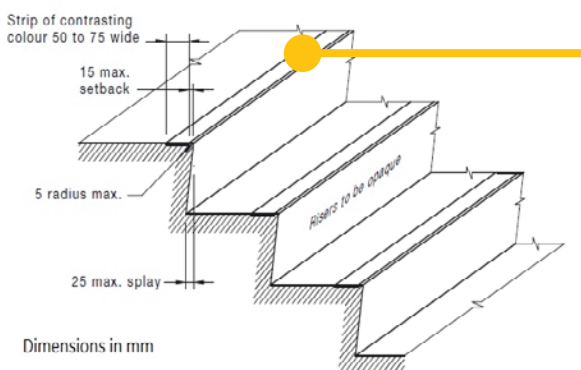

A typical stair nosing profile with nosing strip as in AS1428.1.



BCA-AS1428.1 COMPLIANT NOSING



Benefits of SafeMate BCA-AS1428.1 Compliant Nosing

- BCA compliant stairs, access, and egress pathways
- Enhanced slip, trip, stumble, and fall prevention
- Reduced incidences of slips, trips and falls
- Ensures antislip surface for pedestrians
- Protects front edge (nose) of the steps from wear, tear, breakage, and further polishing/smoothening
- Available in custom length and sizes
- Available in other colours of choice and also metals
- Chemically resistant
- Strongly bonded antislip surface
- Profiles to fit all types of stairs such as vertical riser, curved nosing, bevelled nosing and angled riser
- **Highest antislip rating – R13 and P5 – as tested by NATA approved, accredited testing facility as per Australian and International standards**
- Easy to install
- Remains antislip in wet, oily, greasy, dry and dirty conditions
- Impact resistant metal backing capable of withstanding heavy traffic indoors and outdoors
- Tested to and exceeds the requirements of AS/NZS 4586-2004 & ASTM 02047-04
- Manufactured under strict ISO9001-2008 and American Bureau of Shipping (ABS) standards
- Full 10 year manufacturer warranty

Features of SafeMate BCA-AS1428.1 Compliant Nosing

- High coefficient of friction (~1.2) exceeds BCA requirements for dry as well as wet surfaces
- Fabricated with stainless steel or mild steel backing
- Smooth transition to front edge
- Antislip surface created by embedding hard aluminium oxide grit bonded to metal substrate with our proprietary technique
- Uniform antislip surface throughout the product – flooring, nose, and riser
- Uniform colour achieved via our state-of-the-art epoxy spray technology

ANTI-SLIP CAPPINGS: Standard Dimensions

	(L) A mm	(W) B mm	(R) C mm
Fixings	External & Internal Application		
2	450	70	10
2	600	70	10
3	750	70	10
3	900	70	10
3	1200	70	10

ANTI-SLIP STRIPS: Standard Dimensions

(L) A mm	(W) B mm
External & Internal Application	
450	50
600	50
750	50
900	50
1200	50

Adhesive backed for fast and easy installation.

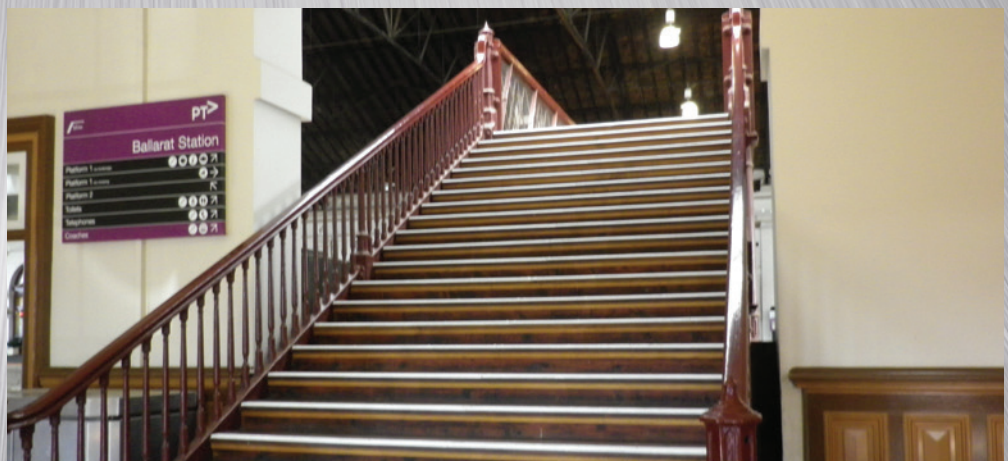

All enquiries: sales@safemate.com

AUS-WIDE: 1800 337 706 | INTERNATIONAL: +61 3 9798 7450

www.safemate.com